



FinishLynx Bronze Package

Quick Start Guide

For EtherLynx Vision Cameras



Bronze - Track

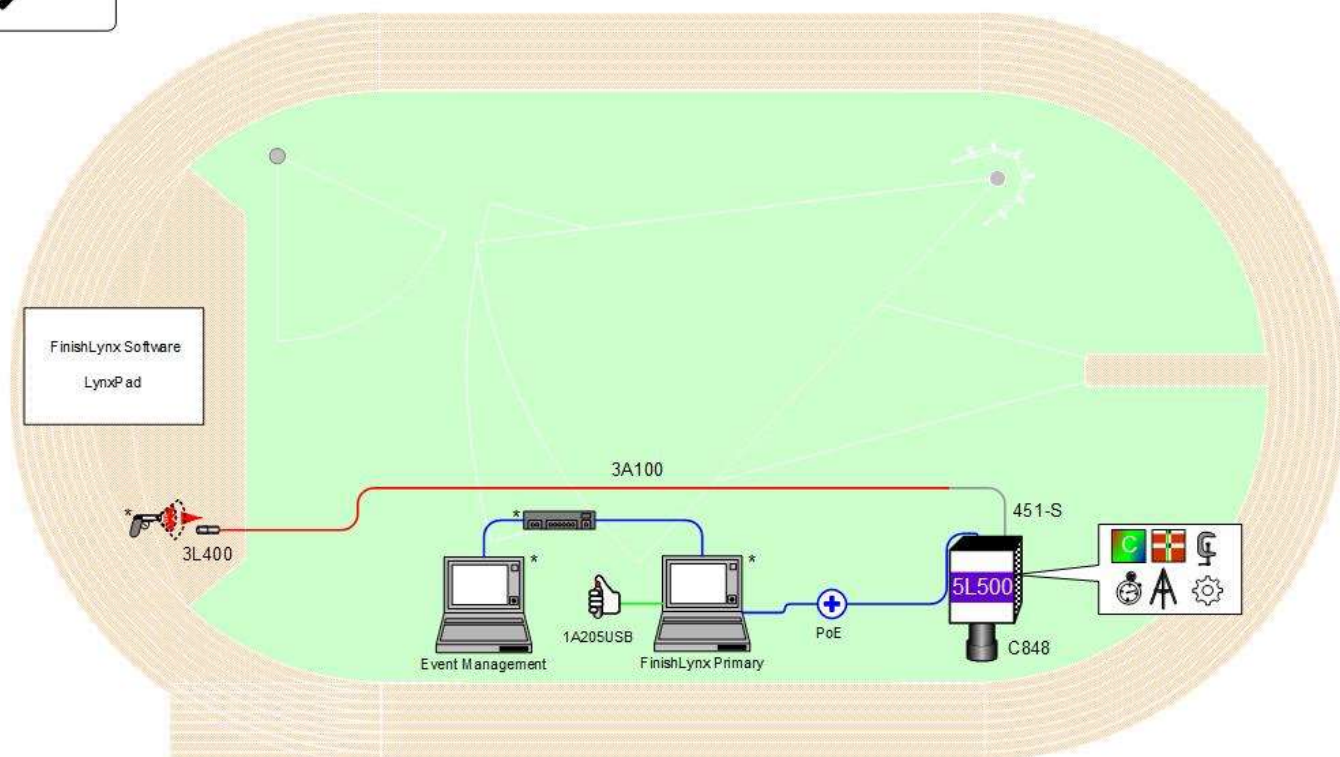

* Computers, Hub, network cable, and starting pistol not included in package

© 1992 – 2024 | Lynx System Developers, Inc. | www.finishlynx.com

Download a copy:



Contact Technical Support:

Email: support@finishlynx.com

Phone: 978-556-978















Join Us Online:

Timer's Group: [facebook.com/groups/finishlynx](https://www.facebook.com/groups/finishlynx)

Facebook: [facebook.com/finishlynx](https://www.facebook.com/finishlynx)

Instagram: @finishlynx

Please verify that your FinishLynx Bronze Package contains all the components pictured here. If something is missing, or if you have questions about setting up your system after following this quick start guide, call: 1-800-989-5969. For additional tech support documents and downloads, visit www.finishlynx.com/support/

Item	Description	Part #	Item	Description	Part #
	Carrying Case	1A207		Normally closed start sensor with light and mount	3L400 3L-Mount
	EtherLynx Vision high sensitivity camera	5L500		500 ft. start sensor cable	3A100
Not pictured	Timer-Enabled option for 5L500 camera	5LTE		DB15 to XLR Connection cable	451-S
	C-Mount 8-48mm f1.2 Manual Zoom Lens	C848		25 ft. Ethernet cables (x2)	C10BT-25
	CS Mount 2.8-10mm P-Iris Lens	CS2810P		Power Injector for Power-over-Ethernet	IDL-PoE
	CS Mount to C Mount Adapter	MCS-C		Capture button	1A205USB
	Geared Head	BG3275		Camera Tripod	BG3036
	Super Head Clamp	BG2909		Lynx USB Flash Drive with FinishLynx32 and LynxPad	5LSW and 9LSW01
<p>Be sure to keep your USB flash drive safe. It includes your Serial Numbers, Software, & Quick-Start Guides. To access the files, insert the flash drive in your computer and click on START.html.</p>					

Items Not Included

- **Laptop or netbook** computer running Microsoft Windows. Your computer needs: 1 available USB port and 1 available Ethernet port.
- Plumb bob and string. The plumb bob is available at your local hardware store, and you can use any type of string, as long as it is at least the width of your track (optional).
- **Printer** (optional)

Introduction

In this QSG, you will learn how to configure the FinishLynx network, set up the EtherLynx Vision camera and align it with the finish line using the EasyAlign software feature. You will also learn how to capture, evaluate, and print a FinishLynx results image, and import a start list created in LynxPad.

For more detailed or advanced instructions, consult the online *FinishLynx Operator's Manual* (help.finishlynx.com) or the technical support section of our website: www.finishlynx.com/support/.

Step 1. Go to the Track

Bring your FinishLynx system (and an assistant) to the track. Make sure there is **power** available for your computers and for the Power-over-Ethernet switch. The EtherLynx Vision camera and the IdentiLynx camera will receive their power via the Ethernet data cables.

Set up a table near the finish line, ideally on the infield if power is available. The finish line should have black lane markers painted or taped on the finish. If not, we suggest you use black matte tape to designate lane lines. This will help you align the camera and get clearer images.

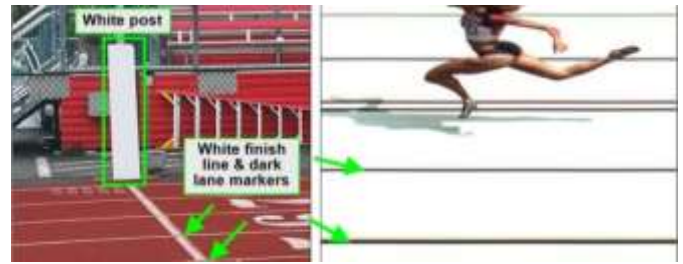

Step 2. Install the Software

A. FinishLynx

Install FinishLynx from the USB thumb drive provided with your system or download the latest version at:

www.finishlynx.com/product/software/finishlynx-results-software/

Follow the instructions on your screen to install FinishLynx. When prompted, enter the serial numbers provided on the flash drive.

1. Start FinishLynx by clicking the Windows **Start** button and selecting **FinishLynx**.

B. LynxPad

Install using the Lynx flash drive or download the latest version of LynxPad at:

www.finishlynx.com/product/event-management/lynxpad/

Follow the instructions on your screen to install LynxPad. When prompted, enter the serial number found inside the Lynx flash drive.

Note: You should **right-click** on the installer and select **Run as Administrator** to install Lynx Pad. If you do not, you will not be able to print from LynxPad.

Step 3. Evaluate a Sample Image

1. Start FinishLynx. Click **File | Open....**
2. Double-click **Sprint.evn** to open the sample event.

Note: This sample is a two-camera image. Your Bronze System uses only one line-scan camera and produces single-camera images.

3. Click the mouse once on the torso of a competitor on the left side of the screen. A red hairline appears. Enter the lane number for the athlete in the identification box.

4. Press the **Enter** key on your computer. The finisher's time appears in the start list above the image.
5. Repeat these steps for all the competitors on the screen. You have just successfully evaluated a race in FinishLynx.
6. Click **File | Close window**. If you want to reuse the image later for practice evaluation, click **No** when asked to save your changes. Close FinishLynx.

Step 4. Configure the Network for Windows 10 & 11

Note: To be completed on both FinishLynx and Meet Management computer.

1. Go to the windows **Control Panel**. On the top right is **View By** with a drop-down arrow. Click the drop-down arrow and choose Small or Large Icons.
2. Double-click **Network and Sharing Center**. They are listed alphabetically by icon name.
3. This will open the **Network and Sharing Center**. On the left is a blue section titled Control Panel Home.
4. Click the **Change Adapter Settings** icon.
5. A new window will open displaying your network connections. Right-click on the **Wireless Network Connection** and select **Disable** from the list of items. This is only necessary for the FinishLynx Capture computer.

6. Right-click on the **Local Area Connection** and select **Properties** from the list of items. A new window will appear with a list of connection items. Select **Internet Protocol Version 4 (TCP/IPv4)** and click the **Properties** button.
7. A Properties window will appear and is typically set to **Obtain an IP address automatically**. Select the radio button for **Use the following IP address**. In the box for IP address, enter 192.168.0.5 for FinishLynx and hit **Tab** key to auto fill in Subnet mask 255.255.255.0. Use 192.168.0.90 for LynxPad.
8. Click **OK** and navigate back to the Control Panel. In the control panel click on the Windows Firewall icon. Under Control Panel Home, on the left, click on **Turn Windows Firewall on or off**.
9. Turn off all Firewalls (Public, Private, Domain).

Step 5. Set up the Camera and Tripod

Set up the tripod in line with the finish line, preferably on the infield and approximately **10 feet back**.

Note: Minimum recommended camera distance from track is 8 feet (at this distance you may not be able to see the feet of the athlete in Lane 1 – being able to see the feet is not a requirement for accurate timing on the Torso of the athlete). If you need to be closer than this, you may have to use the optional 2.8-10mm P-Iris Lens supplied with your Bronze Package. (See last page of QSG for these instructions)

1. Extend the tripod legs so the geared head is approximately 7 ft high.
2. On the near side of the finish line, hold a plumb bob so that it is suspended directly above the middle of the finish line. This is the **plumb line**, shown as **a** in the image below.
3. Tie string to the screw on the top of the tripod head. Have your assistant take the other end of the string to the far side

of the finish line and hold the string taught. This is the **sight line**, shown as **b** in the image below.

4. Move the tripod to the left or right until the plumb line and sight line touch at position **C** in the image below. The tripod is now in the plane of the finish line.

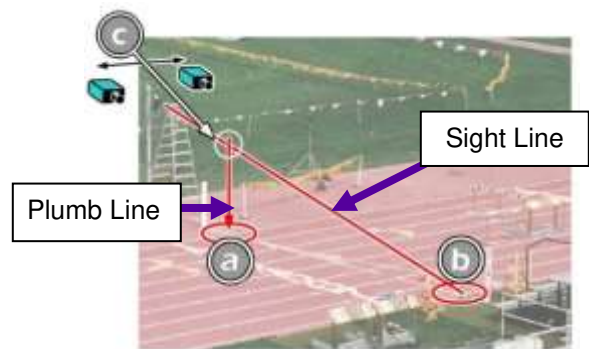

Step 6. Attach the Camera to the Tripod

1. Secure the geared head to the top of the tripod.
2. Note how the camera mounting plate is attached to the top of the geared head. Then, pull back on the lever at the top of the geared head to release the mounting plate.



3. Tighten the mounting plate to the bottom of the camera by turning the screw with a flathead screwdriver.
4. Attach the camera and mounting plate to the tripod by clicking the mounting plate into place on the geared head.
5. With the camera lens lined up with and facing the finish line, make minor adjustments to the tripod legs so both bubbles on the tripod are centered.
6. When you are finished, your camera assembly should resemble the picture below.
7. Turn the black knob on the geared head that controls the **tilt** of the camera so that it is at about a 30-degree angle to the ground.

Step 7. Connect the Cables

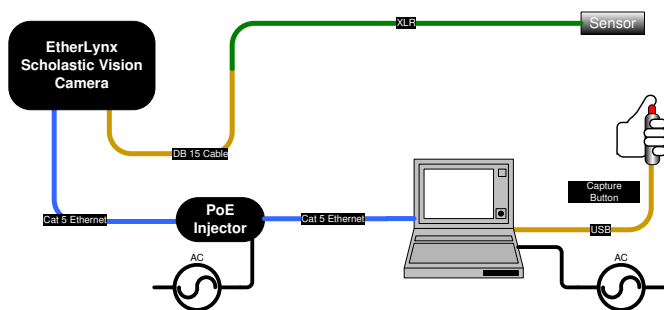

1. Connect an Ethernet cable between the back of the camera labeled **POE 10/100/1000** to the port labelled **Out** on the Power-over-Ethernet injector.
2. Connect an Ethernet cable to the network connection on your computer and the other end to a port labelled **In** on the Power-over-Ethernet injector.
3. Connect DB15 to XLR Connection cable to the port on the back of the camera labeled **Connection Box**.

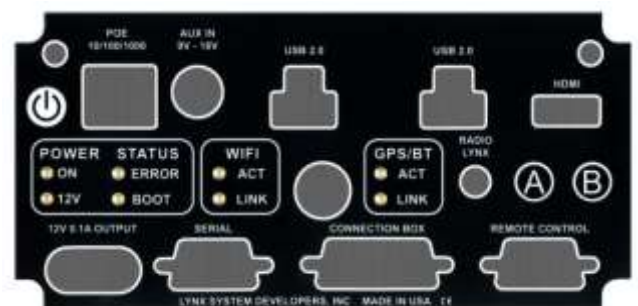

4. Connect the male end of the start sensor cable to the DB15 to XLR Connection cable. Attach the start sensor to the other end of the cable and keep the start sensor close by.
5. Connect the capture button to a USB port on your computer.
6. Turn on the camera by pressing and holding the black power button on the back.

Step 8. Align the EtherLynx Camera

Note: The EtherLynx Vision camera can be aligned using either 1-D mode or 2-D EasyAlign mode. We recommend using EasyAlign. If you are using an older model EtherLynx camera, however, it must be aligned using classic 1-D mode.

NOTE If running a wireless Ethernet card on your computer, we recommend that you disable it while the camera is booting.

Start FinishLynx. Wait while the green status bar in the lower right corner of the screen completes its cycle.

Align Vision Camera in EasyAlign 2-D Video Mode

1. **Activate EasyAlign** by clicking on the 2-D Align Icon  in the top left-hand corner of the FinishLynx **Hardware Control** screen.

The icon turns green  and the 2-D video viewer appears within the software. The 2-D viewer makes it easy to see how your camera is aligned on the finish. **The goal is to align the green vertical line with the painted finish line and near its front edge.**

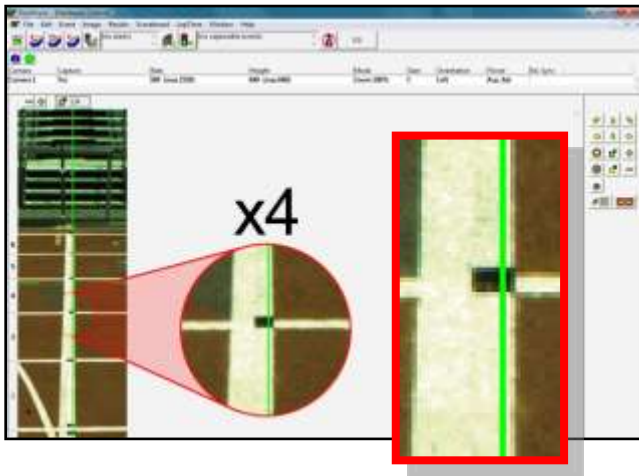

2. **Adjust Camera Orientation**

Use the tripod's **Tilt**, **Pan**, and **Swivel** knobs to adjust the camera orientation of the camera on the finish. You want to ensure that the green vertical line is perfectly aligned on the white finish line and that all lanes are visible in the viewer.

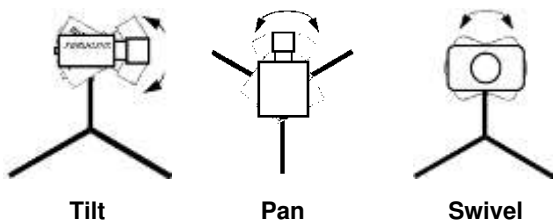



Have your assistant run through the finish line and watch where he/she appears on the computer monitor. The goal is for the runner's torso to be fully visible in both the inside and outside lanes. Once the camera position is correct, you can then optimize the remote lens settings.

3. **Adjust & Optimize Lens Settings**



- **Adjust lens aperture ring** to control the amount of light in the lens. If your picture looks too white or washed out, turn the aperture ring to a higher f-number, to let less light in.
- **Adjust lens focus ring to infinity** (∞). This ensures your **Far Focus** (lanes farthest from camera) appears crisp.

After your far lanes appear in focus, ensure that your near lanes are similarly in focus as well. This will usually be the case automatically. Note: If you are having a hard time getting crisp focus, try opening your lens iris and allowing the AGC to drop closer to zero

4. Once the camera appears to be aligned, **Click**, the green alignment  icon to close 2-D alignment and then click on the red 1-D alignment icon .

You will know when your camera is aligned on the finish line because the 1-D image will be primarily white. See image below for proper 1-D alignment.

If you followed the steps closely in 2-D align, the camera should already be aligned in 1-D mode as well. The 1-D image should look similar to the following screen capture:



5. **Set White Balance**
 - a. Right-click and draw a box around a small amount of the white image.
 - b. Click . White balance is now set.

Step 9. Adjust the Camera Settings

1. Click **Camera Settings Icon**  to open the Camera Settings dialog.
2. Select the **Setup** tab:
 - a. **Name:** Enter a name to identify the camera(s)
 - b. **Image Orientation:** Select the correct orientation for finish (infield would be Left orientation)
 - c. **Identify By:** Select Lane for track competition
 - d. **Lanes:** Enter the number of lanes on the track; the remaining should be left as default.
3. Click **OK** to close the **Camera Settings** and it is advised to restart the FinishLynx software.

Step 10. Create a Shared Directory for FinishLynx and LynxPad

1. Right-click on your computer desktop and select **New | Folder**. When the **New Folder** appears, change the name to **Practice competition**.
2. In FinishLynx, click **File | Options....** Click the **Browse** button on the **Event Directory:** and navigate to the **Practice competition** directory you just created.
3. Still in FinishLynx, click the **Database** tab. Click the **Browse...** button next to the **Output Directory:** and navigate to the **Practice competition** directory. Then, click **Ok**.
4. Now, start LynxPad by clicking the Windows **Start** button and then **LynxPad**.
5. Click **File | Options...** and **uncheck** the **Load Existing Results on Program Start** box. Then, click **Ok**.
6. Open the sample competition by clicking **File | Open**. Navigate to **C:\LynxPadData\Sample** and then double-click the **lynx.cmp** file. A practice competition opens on the screen.
7. Still in LynxPad, click **File | Options....** Click the **Browse** button next to the **Directory:** text field. Navigate to the **Practice competition** file you created earlier. Select it and click **Ok**. Click **Apply** and then click **Ok** again.
8. Still in LynxPad, click **File | Save as...** and navigate to the **Practice competition** folder. Then, click **Ok**. Now FinishLynx can get start lists created in LynxPad, and LynxPad can import results generated by FinishLynx.



Step 11. Use FinishLynx with LynxPad Data

1. In FinishLynx, click  to load the schedule of events from LynxPad. The **Go To Event** dialog appears.
2. Click the **Load Schedule** button once. Click the drop-down list under the **Load Schedule** button. A list of events appears. Click to select the "**110 Meter Hurdles Men (9, 3, 1)**" event in the list, and then click **Ok**. The first heat of the third round of the men's 110m hurdles opens on the FinishLynx screen.
3. Either use a starting gun, or knock the sensor sharply against a hard object - this simulates the firing of the starting gun and starts the yellow FinishLynx timer.
4. Have your assistant run through the finish line while you press down and hold the red capture button to capture the image. Release the button as soon as he/she has run completely through the finish line.
5. Practice evaluating the image by following the same steps you followed earlier in Step 3.
6. Click **File | Save** to save the race to the **Practice competition** directory.
7. Crop space between competitors in your FinishLynx image by right-clicking and drawing a box around the unwanted space. Release the mouse button and select **Crop** from the dialog that appears.
8. **(Optional)** Print the results and a portion of the FinishLynx image by right-clicking on the image and drawing a box around the portion you want to appear in your printout. For example, the first place finisher or a close finish between two competitors. Click **Ok** and then select the printer from the **Print** dialog to print the image and results.
9. Click **File | Close window** and then click **Yes** to save changes you made to the FinishLynx image when you cropped it.
10. In LynxPad, click to highlight **Men 110 Meter Hurdles** in the **Events** window. The start list appears in the **Heats** window.
11. Still in LynxPad, click **Competition | Refresh All Results**. The results from the race you just evaluated appear in LynxPad.

Optional: Using the 2.8-10mm P-Iris Lens**Focus Adjuster****Zoom Adjuster**

First, connect the lens cable to the Remote port on the back of the camera. Then, configure your camera settings to use the 2.8-10mm P-Iris lens: in FinishLynx, access the camera settings by clicking . Under the Setup tab, locate the **Iris Type** setting and select the *P-Iris* radio button. Click Ok.

Iris Type: Normal P-Iris

Remotely adjust lens aperture to control the amount of light in the lens. If your picture looks too white or washed out, use the Close Iris button  in FinishLynx to let less light in. Likewise, if your picture looks too dark, use the Open Iris button  in FinishLynx to let more light in. To enable the Auto Iris feature: click  | Parameters tab; check Auto Iris, and then click OK. FinishLynx will now automatically remotely open and close the iris depending on the amount of light.

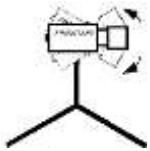

Tilt



Pan

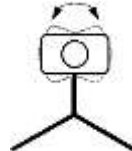



Swivel

Note: By default, the iris will be in the *closed* position, so it is normal for the image in FinishLynx to be very dark or black at first, until you open the iris.

Manually adjust lens focus and zoom rings. This lens is a *varifocal* lens, meaning it will not stay in focus when you change the zoom. This step will require some fine tuning to

get the proper zoom and focus in order to achieve a good image.

- Once the camera appears to be aligned, click the green alignment  icon to close 2D alignment and then click on the red 1-D alignment icon . You will know when your camera is aligned on the finish line because the 1-D image will be primarily white. See image below for proper 1-D alignment.

If you followed the steps closely in 2-D align, the camera should already be aligned in 1-D mode as well. The 1-D image should look similar to the following screen capture:



Note: If your picture looks washed out by too much light, turn the aperture ring to a higher f-number to let less light in.

- Have your assistant run through the finish line and watch where they appear on the computer monitor. The goal is for the runner's torso to be fully visible in both the inside and outside lanes. Now, have your assistant run through the inner-most and outer-most lanes. Adjust the **tilt** of the camera until they are clearly visible on both ends of the finish line.
- Note:** It may be necessary to move the camera further back from the track if you cannot see all lanes in the image.
- After the image on the computer shows a white background and black lane lines and your assistant appears in the inner and outer-most lanes, adjust the camera lens focus again until all lanes appear crisp and in focus.

Looking for more resources? Visit our [YouTube Channel](https://www.youtube.com/finishlynx) (www.youtube.com/finishlynx) for setup and support videos.

Notes: