



EtherLynx Vision Cameras

Quick Start Guide



Download a copy:



Contact Technical Support:

Email: support@finishlynx.com

Phone: 978-556-978





Join Us Online:

Timer's Group: facebook.com/groups/finishlynx











Facebook: facebook.com/finishlynx

Instagram: [@finishlynx](https://instagram.com/finishlynx)

Please verify that your FinishLynx Bronze Package contains all the components pictured here. If something is missing, or if you have questions about setting up your system after following this quick start guide, call: 1-800-989-5969. For additional tech support documents and downloads, visit www.finishlynx.com/support/

Item	Description	Part #	Item	Description	Part #
	EtherLynx Vision high sensitivity camera	5L500		Carrying Case	1A207
	Power Injector for Power-over-Ethernet	IDL-PoE		25 ft. Ethernet cables (x2)	C10BT-25
	CS Mount 2.8-10mm P-Iris Lens	CS2810P*	*NOTE: If you are using this CS-Mount lens, DO NOT USE the C-Mount adaptor shown below		

Optional Items shown below:

	C-Mount 8-48mm f1.2 Manual Zoom Lens	C848		C-Mount 8-48mm f1.2 Motorized Zoom Lens	C848M
	CS Mount to C Mount Adapter	MCS-C		Connection Box	C-Box
	Geared Head	BG3275		Connection Box cable	451
	Camera Tripod	BG3036		Capture button	1A205USB
	Super Head Clamp	BG2909		Lynx USB Flash Drive with FinishLynx32 and LynxPad	5LSW and 9LSW01
	Remote positioner	2L102			
Be sure to keep your USB flash drive safe. It includes your Serial Numbers, Software, & Quick-Start Guides. To access the files, insert the flash drive in your computer and click on START.html.					

Items Not Included

- **Laptop or netbook** computer running Microsoft Windows. Your computer needs: 1 available USB port and 1 available Ethernet port.
- Plumb bob and string. The plumb bob is available at your local hardware store, and you can use any type of string, as long as it is at least the width of your track (optional).
- **Printer** (optional)

Introduction

In this QSG, you will learn how to configure the FinishLynx network, set up the EtherLynx Vision camera and align it with the finish line using the EasyAlign software feature.

For more detailed or advanced instructions, consult the online *FinishLynx Operator's Manual* (help.finishlynx.com) or the technical support section of our website: www.finishlynx.com/support/.

Step 1. Go to the Track

Bring your FinishLynx system (and an assistant) to the track. Make sure there is **power** available for your computers and the Power-over-Ethernet switch. The EtherLynx Vision camera will receive their power via the Ethernet data cables.

Set up a table near the finish line, ideally on the infield if power is available. The finish line should have black lane markers painted or taped on the finish. If not, we suggest you use black matte tape to designate lane lines. This will help you align the camera and get clearer images.



Step 2. Install the Software

1. Install FinishLynx from the USB provided with your system or download the latest version at:

www.finishlynx.com/product/software/finishlynx-results-software/

2. Follow the instructions to install FinishLynx. When prompted, enter the serial numbers provided on the flash drive.
3. Start FinishLynx by clicking the Windows **Start** button and selecting **FinishLynx**.

Step 3. Evaluate a Sample Image

1. Start FinishLynx. Click **File | Open...**
2. Double-click **Sprint.evn** to open the sample event.

Note: This sample is a two-camera image.

3. Click once on the torso of a competitor on the left side of the screen. A red hairline appears. Enter the lane number for the athlete in the identification box.

4. Press **Enter**. The finisher's time appears in the start list above the image.
5. Repeat these steps for all competitors on the screen. You have successfully evaluated a race in FinishLynx.
6. Click **File | Close window**. If you want to reuse the image later for practice evaluation, click **No** when asked to save your changes. Close FinishLynx.

Step 4. Configure the Network for Windows 10 & 11

Note: Sections 1 and 2 should be completed on both FinishLynx and Meet Management computer.

1. Go to the windows **Control Panel**. On the top right is **View By** with a drop-down arrow. Click the drop-down arrow and choose Small or Large Icons.
2. Double-click **Network and Sharing Center**. They are listed alphabetically by icon name.
3. On the left is a blue section titled Control Panel Home. Click the **Change Adapter Settings** icon.
4. A new window will open displaying your network connections. Right-click the **Wireless Network Connection** and select **Disable** from the list. This is only necessary for the FinishLynx Capture computer.

5. Right-click on **Local Area Connection** and select **Properties** from the list. A new window will appear with a list of connection items. Select **Internet Protocol Version 4 (TCP/IPv4)** and click the **Properties** button.
6. A Properties window will appear and is typically set to **Obtain an IP address automatically**. Select the radio button for **Use the following IP address**. In the box for IP address, enter 192.168.0.5 for FinishLynx and hit **Tab** key to auto fill in Subnet mask 255.255.255.0
7. Click **OK** and navigate back to the Control Panel. In the control panel click the Windows Firewall icon. Under Control Panel Home, on the left, click **Turn Windows Firewall on or off**.
8. Turn off both Home and Public Firewalls (Domain for Windows Pro).

Step 5. Set Up the Camera and Tripod

Set up the tripod in line with the finish line, preferably on the infield and approximately **10 feet back**.

Note: Minimum recommended camera distance from track is 8 feet (at this distance you may not be able to see the feet of the athlete in Lane 1 – being able to see the feet is

not a requirement for accurate timing on the Torso of the athlete). If you need to be closer than this, you may have to use the optional 2.8-10mm P-Iris Lens supplied. (See last page of QSG for these instructions)

1. Extend the tripod legs so the geared head is approximately 7 ft high.
2. On the near side of the finish line, hold a plumb bob so that it is suspended directly above the middle of the finish line. This is the **plumb line**, shown as **a** in the image below.
3. Tie string to the screw on the top of the tripod head. Have your assistant take the other end of the string to the far side of the finish line and hold the string taut. This is the **sight line**, shown as **b** in the image.
4. Move the tripod to the left or right until the plumb line and sight line touch at position **c** in the image. The tripod is now in the plane of the finish line.

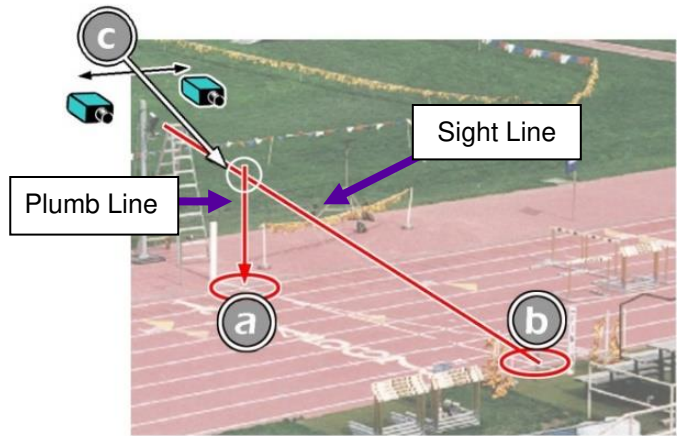

Step 6. Attach the Camera to the Tripod

1. Secure the geared head to the top of the tripod.
2. Note how the camera mounting plate is attached to the top of the geared head. Then, pull back on the lever at the top of the geared head to release the mounting plate.
3. Tighten the mounting plate to the bottom of the camera by turning the screw with a flathead screwdriver.
4. Attach the camera and mounting plate to the tripod by clicking the mounting plate into place on the geared head.
5. With the camera lens lined up with and facing the finish line, make minor adjustments to the tripod legs so both bubbles on the tripod are centered.

6. When you are finished, your camera assembly should resemble the picture below.
7. Turn the black knob on the geared head that controls the **tilt** of the camera so that it is at about a 30-degree angle to the ground.



Step 7. Connect the Cables

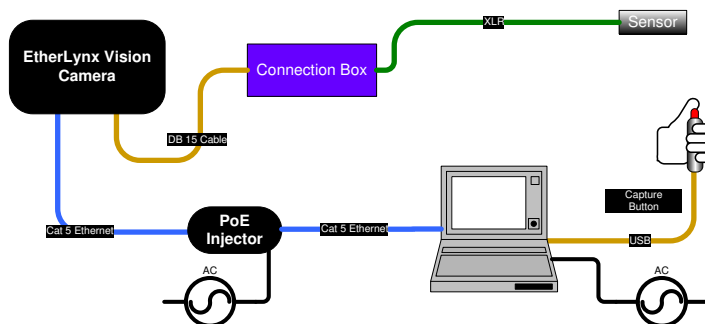

1. Connect the female end of connection box cable to the port on the back of the camera labeled **Connection Box** and the male end to the left side of the connection box.
2. Connect an Ethernet cable between the back of the camera labeled **POE 10/100/1000** to the port labeled **Out** on the Power-over-Ethernet injector.
3. Connect an Ethernet cable to the network connection on your computer and the other end to a port labeled **In** on the Power-over-Ethernet injector.

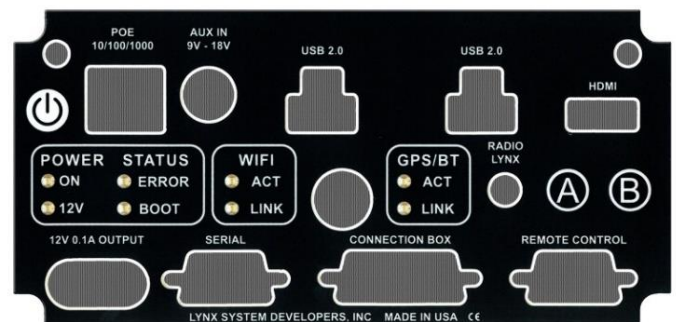

4. Connect the male end of the start sensor cable to the connection box where it says **Start**. Attach the start sensor to the other end of the cable and keep the start sensor close by.
5. Connect the capture button to a USB port on your computer.
6. Turn on the camera by pressing and holding the black power button on the back.

Step 8. Align the EtherLynx Camera

Note: The EtherLynx Vision camera can be aligned using either 1-D mode or 2-D EasyAlign mode. We recommend using EasyAlign. If you are using an older model EtherLynx camera, however, it must be aligned using classic 1-D mode.

NOTE: If running a wireless Ethernet card on your computer, we recommend that you disable it while the camera is booting.

Start FinishLynx. Wait while the green status bar in the lower right corner of the screen completes its cycle.

Align Vision Camera in EasyAlign 2-D Video Mode

1. **Activate EasyAlign** by clicking on the 2-D Align Icon  in the top left-hand corner of the FinishLynx **Hardware Control** screen.

The icon turns green  and the 2-D video viewer appears within the software. The 2-D viewer makes it easy to see how your camera is aligned on the finish. **The goal is to align the green vertical line with the painted finish line and near its front edge.**

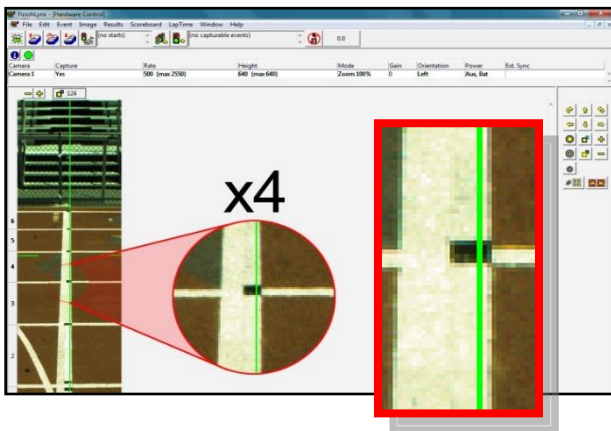

2. **Adjust Camera Orientation**

Use the tripod's **Tilt**, **Pan**, and **Swivel** knobs to adjust the orientation of the camera on the finish. You want to ensure the green vertical line is perfectly aligned on the white finish line and all lanes are visible in the viewer.

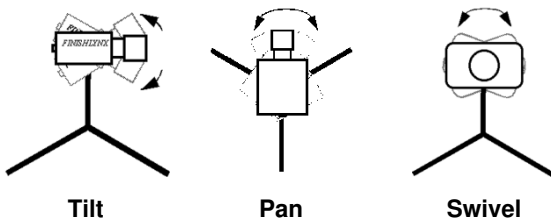

Have your assistant run through the finish line and watch where they appear on the computer monitor. The goal is for the runner's torso to be fully visible in both



the inside and outside lanes. Once the camera position is correct, you can then optimize the remote lens settings.

3. **Adjust & Optimize Lens Settings**



- **Adjust lens aperture ring** to control the amount of light in the lens. If your picture looks too white or washed out, turn the aperture ring to a higher f-number, to let less light in.
- **Adjust lens focus ring to infinity (∞).** This ensures your **Far Focus** (lanes farthest from camera) appears crisp.

After your far lanes appear in focus, ensure that your near lanes are similarly in focus also. This will usually be the case automatically. If you are having a hard time getting crisp focus, try opening your lens iris and allowing the AGC to drop closer to zero.

4. Once the camera appears to be aligned, click the green alignment  icon to close 2-D alignment then click the red 1-D alignment icon .

If you followed the steps closely in 2-D align, the camera should already be aligned in 1-D mode as well. The 1-D image should look similar to the following screen capture:

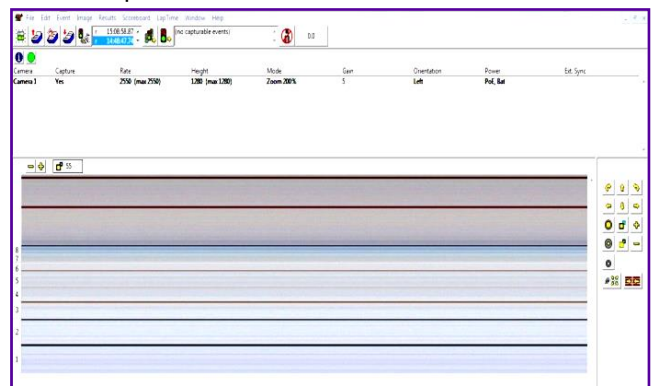

5. **Set White Balance**

- a. Right-click and draw a box around a small amount of the white image.
- b. Click . White balance is now set.

Step 9. Adjust the Camera Settings



1. Click **Camera Settings Icon**  to open the Camera Settings dialog.
2. Select the **Setup** tab:
 - a. **Name:** Enter a name to identify the camera(s)
 - b. **Image Orientation:** Select the correct orientation for finish (infield would be Left orientation)
 - c. **Identify By:** Select Lane for track competition.
 - d. **Lanes:** Enter the number of lanes on the track; the remaining should be left as default.
3. Click **OK** to close the **Camera Settings** and it is advised to restart the FinishLynx software.

Optional: Using the 2.8-10mm P-Iris Lens



First, connect the lens cable to the Remote port on the back of the camera. Then, configure your camera settings to use the 2.8-10mm P-Iris lens: in FinishLynx, access the camera settings by clicking . Under the Setup tab, locate the **Iris Type:** setting and select the *P-Iris* radio button. Click Ok.



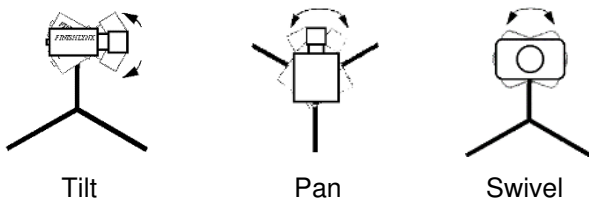

Remotely adjust lens aperture to control the amount of light in the lens. If your picture looks too white or washed out, use the Close Iris button  in FinishLynx to let less light in. Likewise, if your picture looks too dark, use the Open Iris button  in FinishLynx to let more light in. To enable the Auto Iris feature: click  | Parameters tab; check Auto Iris, and then click OK. FinishLynx will now automatically remotely open and close the iris depending on the amount of light.



Note: By default, the iris will be in the *closed* position, so it is normal for the image in FinishLynx to be very dark or black at first, until you open the iris.

Manually adjust lens focus and zoom rings. This lens is a *varifocal* lens, meaning it will not stay in focus when you

change the zoom. This step will require some fine tuning to get the proper zoom and focus to achieve a good image.

Once the camera appears to be aligned, click the green alignment  icon to close 2-D alignment then click the red 1-D alignment icon . You will know your camera is aligned on the finish line because the 1-D image will be primarily white. See image below for proper 1-D alignment.

If you followed the steps closely in 2-D align, the camera should already be aligned in 1-D mode as well.

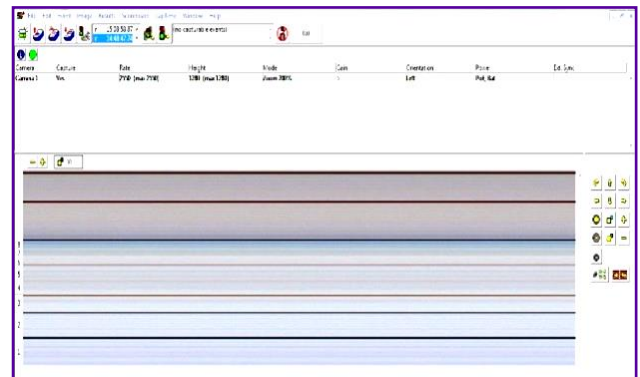

Note: If your picture looks washed out by too much light, turn the aperture ring to a higher f-number to let less light in.

Have your assistant run through the finish line and watch where they appear on the computer monitor. The goal is for the runner's torso to be fully visible in both the inside and outside lanes. Now, have your assistant run through the inner-most and outer-most lanes. Adjust the **tilt** of the camera until they are clearly visible on both ends of the finish line.

Note: It may be necessary to move the camera further back from the track if you cannot see all lanes in the image.

After the image on the computer shows a white background and black lane lines and your assistant appears in the inner and outer-most lanes, adjust the camera lens focus ring again until all lanes appear crisp and in focus.

Looking for more resources? Visit our [YouTube Channel](https://www.youtube.com/finishlynx) (www.youtube.com/finishlynx) for setup and support videos.